

# Brugarolas

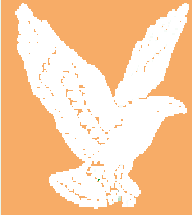

Industrial Lubricants



## HIGH PRESSURE ALUMINIUM DIE CASTING



## BASIC PRESSURE INJECTION PROCESS IN A PRESS OF HORIZONTAL COLD CHAMBER

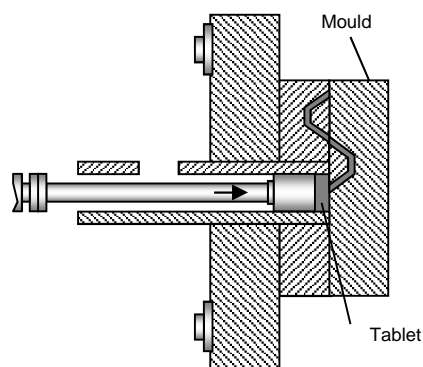
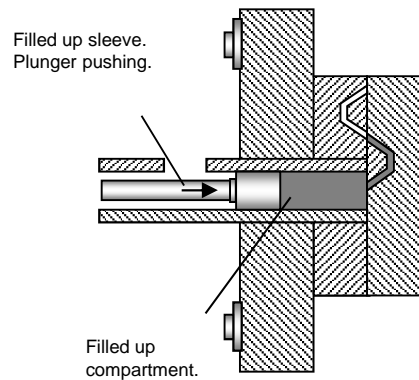
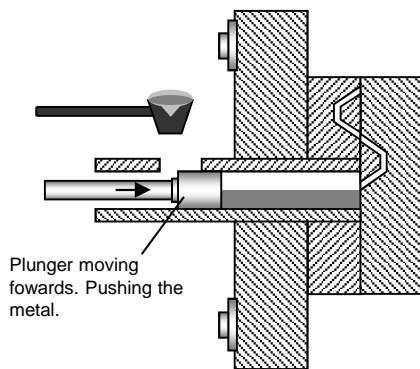
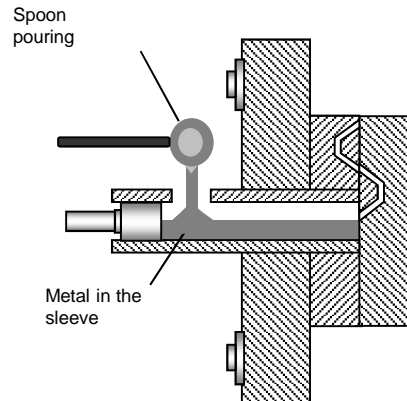
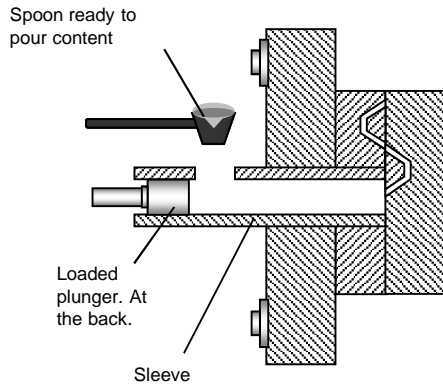

- 1) Closed mould, the material is brought to the sleeve.
- 2) The material is placed in the sleeve.
- 3) The plunger, at a low speed, starts pushing with until the sleeve is full and the material reaches the canal. (first injection phase)
- 4) The plunger changes to a much higher speed and the material starts to fill the figure (second injection phase)
- 5) The mould is "full" and the plunger presses with great strength with still liquid material. (third phase of injection)
- 6) The machine opens and releases the part.



## Die casting products

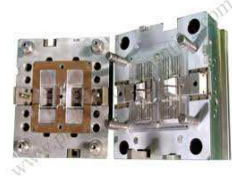

### WATER SOLUBLE MOULD RELEASER

<i>Product</i>	<i>Specifications</i>
BESTRIL 1200 MOD	Synthetic compound, for Aluminium, Zamak and Magnesium
BESTRIL 1290 MOD	Synthetic compound, for Aluminium, Zamak and Magnesium
BESTRIL 1295	Synthetic compound, for Aluminium, Zamak and Magnesium
BESTRIL 2030	Mineral oil, for Aluminium, Zamak and Magnesium
BESTRIL 2040	Synthetic compound, for Aluminium, Zamak and Magnesium.
BESTRIL 2070	Mineral oil, for Aluminium, Zamak and Magnesium.

### PURE RELEASING FLUIDS

<i>Product</i>	<i>Specifications</i>
BESTRIL 2010	Mineral oil, 500 cSt a 40°C, for Aluminium
BESTRIL 2050	Pure oil. Flash point 70°C, for Zamak

### PLUNGER LUBRICANTS

<i>Product</i>	<i>Specifications</i>
BESTRIL 80 AG	Graphite oil, 320 cSt at 40°C
BESTRIL FSP-320	Mineral oil, 320 cSt at 40°C
BESTRIL FSP-550	Mineral oil, 550 cSt at 40°C
BESTRIL FSP-1	White color solid lubricant , 1mm grain
BESTRIL FSP-1G	Black color solid lubricant, 1mm grain
BESTRIL FSP-EW	Fluid for container inner lubrication

### EJECTORS AND DISTRIBUTORS PASTE

<i>Product</i>	<i>Specifications</i>
BESLUX GRAFOL HT PASTE	Graphite paste
BESLUX GRAFOL AL PASTE	Aluminium paste



Industrial Lubricants

# HIGH PRESSURE ALUMINIUM DIE CASTING



## GENERAL MAINTENANCE LUBRICATING PRODUCTS



<i>Product</i>	<i>Specifications</i>
FLUID DRIVE HLP-46	Hydraulic oil DIN, HLP, ISO VG 46
HIDROSECUR A-1100	Fire resistant hydraulic fluid ISO HFC, VG-46
HIDROSECUR D-46	Fire resistant hydraulic fluid ISO HFDU, VG-46
BESTERM HT	Heat transfer Fluid
BESADEP 220	Slideway oil, ISO VG 220
BESTRIL 570	Stamping press oil
FSP DOSIFICACION EQUIPTMENT	Dispenser equipment with pressure pump for soluble releases

## MACHINING FLUIDS

<i>Product</i>	<i>Specifications</i>
SERVOL 512 IN	Water soluble fluid for Aluminium machining. Water hardness up to 30°HF
SERVOL 533	Water soluble fluid for Aluminium machining. Water hardness from 20 up to 70°HF



Industrial Lubricants

BRUGAROLAS, S.A.  
Camino de la Riera 36-44  
Polígono Industrial Cova Solera  
08191 Rubí (Barcelona)  
Tlf: 93 588 31 00  
Fax: 93 588 31 01  
E-mail: [comercial@brugarolas.com](mailto:comercial@brugarolas.com)  
Web: [www.brugarolas.com](http://www.brugarolas.com)



January 2016